



BULUNMAZ

PROFESSIONAL JEWELRY TECHNOLOGIES

CNC MACHINES

CATALOGUE / 2020



Banglemaster



Ringmaker



Excalibur

**BULUNMAZ**passion for *precision*

CNC Machines for Jewelry Production

idea

We had long years of experience in production, R&D and marketing in jewelry industry. All these experiences led us the way to understand what modern goldsmiths need for their designs and production lines. Today, we are under siege of various technologies in our daily lives, such as internet of things, artificial intelligence and incredible material technologies. All these developments brought us to the idea of starting a long journey of designing and production of CNC machines for jewelry industry.

process

With an eternal enthusiasm and a strong team, we started our design and production facility in Istanbul, the financial capital of Turkey. Today with a strong team, we are working hard to understand, develop and produce the latest technologies for jewelry industry. You are always welcome to visit our production facility in Istanbul and world-wide showrooms.

destination

"Coming together is a beginning; keeping together is process, working together is success" - as Henry Ford says. We work hard to strengthen our team and partners, implement modern technologies to our machines and making the things easy and affordable for jewelry industry.

▶ RINGMAKER



3 AXIS CNC MACHINE FOR RING AND BANGLE PRODUCTION

- ▶ Double 40.000 rpm 1.2 kw vertical spindles
12.000 rpm 0.75 kw horizontal spindle
- ▶ Optional 50.000 rpm 2.8 kw automatic tool changer spindle
- ▶ 70.000 rpm pneumatic spindle for high speed engraving
- ▶ Built-in hammering attachment
- ▶ Mitsubishi servo motors
- ▶ PC based controller software. Easy to convert, track and process. Multi languages support
- ▶ Free training for controller software and life time support for design software
- ▶ Full dust collection, totally isolated working area
- ▶ Ready infrastructure to be updated to Ringmaker IV 4 axis



RINGMAKER 3 AXIS BANGLE & RING SAMPLES



▶ B30



MACHINABLE PRODUCTS

Wedding rings, bangles, round objects

TECHNICAL SPECIES

- ▶ **VERTICAL MOTOR** 2x40.000 rpm 1.2 kw MTC Spindles
- ▶ **HORIZONTAL MOTOR** 12.000 rpm, 1,1 kw MTC spindle
- ▶ **EXTRA HEAD** 70.000 rpm pneumatic spindle, hammering attachment
- ▶ **POWER** 220V, 50/60 Hz, 3.5 kw
- ▶ **MOTORS** Servo motors (400W x 2, 750W x 1 Mitsubishi)
- ▶ **WORKING AREA** X:150mm, Y:360°, Z:150mm
- ▶ **SIZE / WEIGHT** 75x75x185cm (body) / 300 kg
- ▶ **PERIPHERALS** 4 kw UPS, 100 lt. Compressor
- ▶ **CONTROLLER** PC Control / Ringmaker Software

PACKING DETAILS

- ▶ **HORIZONTAL** 190x115x100 cm
- ▶ **VERTICAL** 115x85x200 cm
- ▶ **WEIGHT** Net: 300 kg / Gross: 390 kg

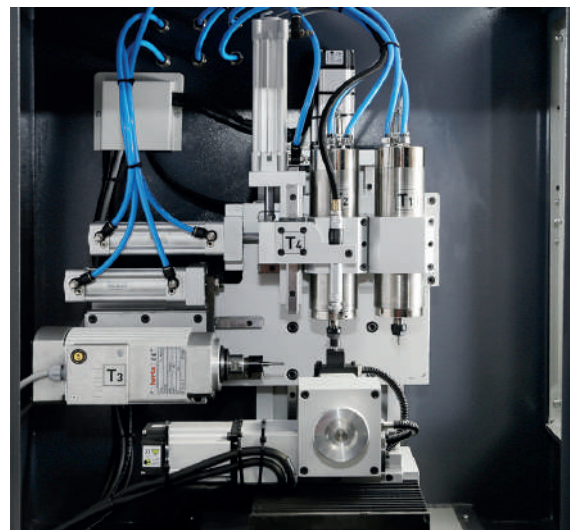
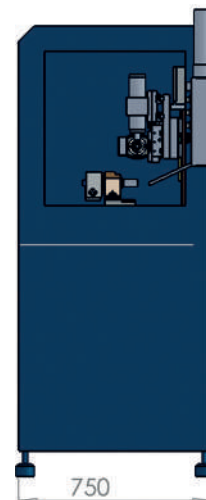
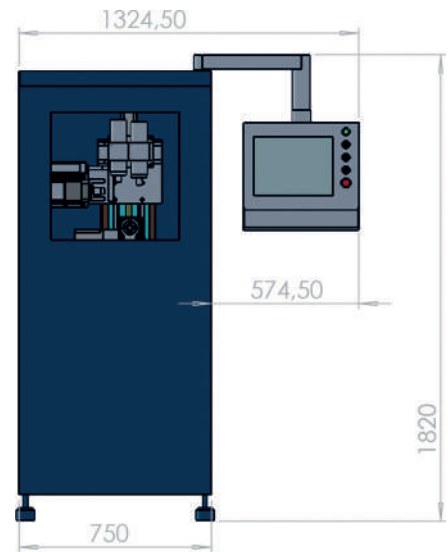

▶ RINGMAKER



4 AXIS CNC MACHINE FOR RING AND BANGLE PRODUCTION

- ▶ Full spindle options of Ringmaker 3 axis base version
- ▶ 360° horizontal diamond cut head
- ▶ Total 6 head that can work continuously
- ▶ Additional 5th axis option for flat pieces working
- ▶ Mitsubishi servo motors
- ▶ PC based controller software. Easy to convert, track and process. Multi languages support
- ▶ Free training for controller software and life time support for design software
- ▶ Full dust collection



RINGMAKER 4 AXIS BANGLE & RING SAMPLES



▶ B35



MACHINABLE PRODUCTS

Wedding rings, bangles, round objects, pendants, various flat items

TECHNICAL SPECIES

- ▶ **VERTICAL MOTOR** 2x40.000 rpm 1.2 kw MTC Spindles
50.000 rpm 2.8 kw automatic tool changer spindle optional
- ▶ **HORIZONTAL MOTOR** 12.000 rpm, 1.1 kw MTC spindle
10.000 rpm 0.75 kw MTC spindle for diamond cut head
- ▶ **EXTRA HEAD** 70.000 rpm pneumatic spindle, hammering attachment
- ▶ **POWER** 220V, 50/60 Hz, 3.5 kw
- ▶ **MOTORS** Servo motors (400W x 3, 750W x 1 Mitsubishi)
- ▶ **WORKING AREA** X:150mm, Y:360°, Z:150mm
- ▶ **SIZE / WEIGHT** 75x75x185cm (body) / 300 kg
- ▶ **PERIPHERALS** 4 kw UPS, 100 lt. Compressor
- ▶ **CONTROLLER** PC Control / Ringmaker Software

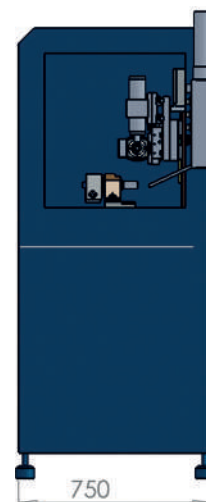
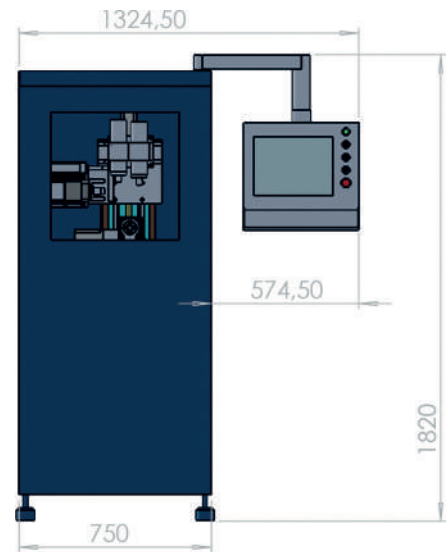

PACKING DETAILS

- ▶ **HORIZONTAL** 190x115x100 cm
- ▶ **VERTICAL** 115x85x200 cm
- ▶ **WEIGHT** Net: 300 kg / Gross: 390 kg

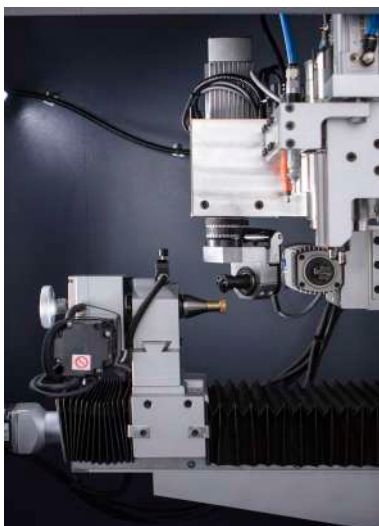

▶ EXCALIBUR

CNC SHEET DECORATION MACHINE WITH MULTIPLE HEADS



- ▶ 50.000 rpm 2.8 kw high precision, heavy duty spindle for rapid engraving
- ▶ Automatic tool changer with taper tool holder
- ▶ 360° horizontal diamond cut head
- ▶ Mitsubishi servo motors
- ▶ Optional ring/bangle attachment
- ▶ Optional surface scanner attachment for ultra-thin ornaments
- ▶ PC based controller software
- ▶ Easy to convert, track and process.
- ▶ Multi languages support, free training
- ▶ Full dust collection, totally isolated working area



EXCALIBUR PRODUCT SAMPLES



▶ B40



MACHINABLE PRODUCTS

Sheet materials from 0.15mm thickness

TECHNICAL SPECIES

- ▶ **VERTICAL MOTOR** 50.000 rpm 2.8 kw automatic tool changer spindle
- ▶ **TOOL CHANGER** 5 tools (10 tools optional)
- ▶ **DIAMOND CUT HEAD** 360° 10.000 rpm 0.75 kw MTC horizontal spindle
- ▶ **EXTRA HEAD** Hammering attachment
- ▶ **POWER** 220V, 50/60 Hz, 3.5 kw
- ▶ **MOTORS** Servo motors (750W x 2, 400W x 2 Mitsubishi)
- ▶ **WORKING AREA** X:300mm, Y:150mm, Z:80mm
- ▶ **SIZE / WEIGHT** 100x70x148cm (body) / 410 kg
- ▶ **PERIPHERALS** 4 kw UPS, 100 lt. Compressor
- ▶ **CONTROLLER** PC Control / Ringmaker Software

PACKING DETAILS

- ▶ **VERTICAL** 140x80x170 cm
- ▶ **WEIGHT** 410 kg / Gross 510 kg

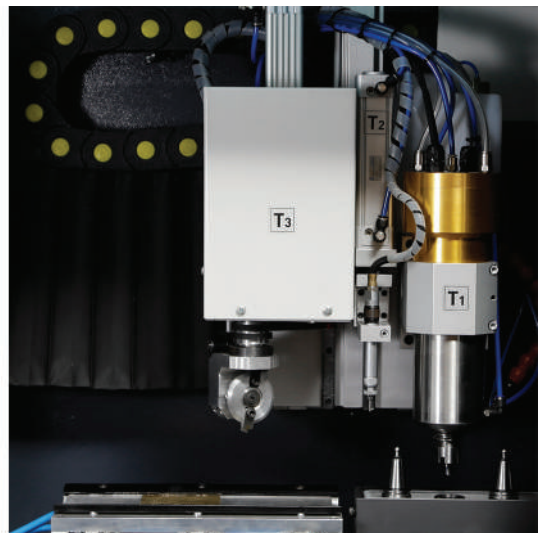
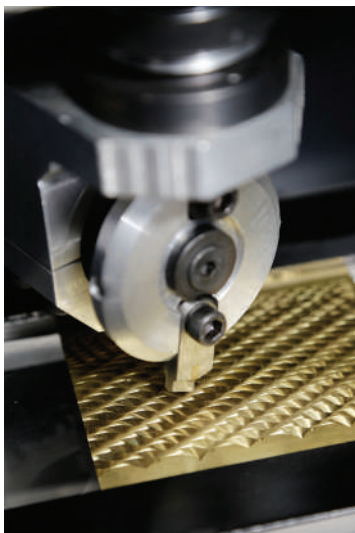
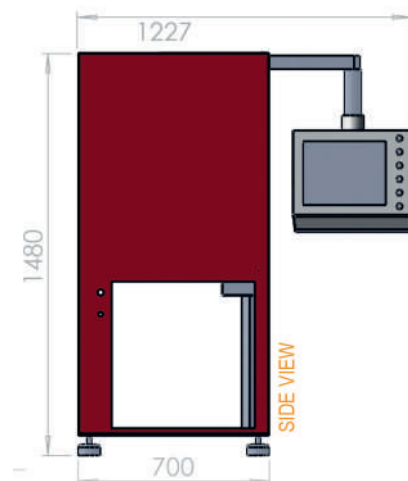
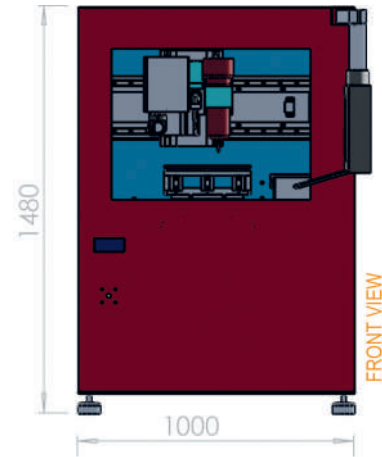

▶ BANGLEMASTER



MULTI AXIS CNC MACHINE FOR BANGLE AND RING PRODUCTION

- ▶ 50.000 rpm 2.8 kw high precision, heavy duty spindle for rapid engraving
- ▶ Automatic tool changer with taper tool holder
- ▶ Mitsubishi servo motors 11 servos for 11 independent moving axis
- ▶ Extra background motors, 360° diamond cutting head, hammering attachment
- ▶ Optional surface scanner for hollow or ultra-thin rings or bangles
- ▶ Optional oil cooling system
- ▶ PC based controller software
- ▶ Easy to convert, track and process.
- ▶ Multi languages support, free training
- ▶ Full dust collection, totally isolated working area



BANGLEMASTER PRODUCT SAMPLES



▶ B50



" Servo motors (750W x 2, 400W x 7, 200W x 2 Mitsubishi) " olarak deęiştirilecek.

MACHINABLE PRODUCTS

Bangles, wedding rings, round objects

TECHNICAL SPECIES

- ▶ **VERTICAL MOTOR** 50.000 rpm 2.8 kw automatic tool changer spindle
- ▶ **TOOL CHANGER** 5 tools (10 tools optional)
- ▶ **HORIZONTAL MOTOR** 12.000 rpm 0.75 kw, MTC
- ▶ **DIAMOND CUT HEAD** 12.000 rpm 0.75 kw / 360°
- ▶ **EXTRA HEAD** Hammering attachment
- ▶ **POWER** 220V, 50/60 Hz, 3.5 kw
- ▶ **MOTORS** Servo motors (750W x 2, 400W x 7, 200W x 2 Mitsubishi)
- ▶ **WORKING AREA** X:500mm, Y:360°, Z:200mm
- ▶ **SIZE / WEIGHT** 120x75x172cm (body) / 800 kg
- ▶ **PERIPHERALS** 6 kw UPS, 100 lt. Compressor
- ▶ **CONTROLLER** PC Control / Banglemaster Software

PACKING DETAILS

- ▶ **VERTICAL** 160x85x200 cm
- ▶ **WEIGHT** 800 kg / Gross 950 kg

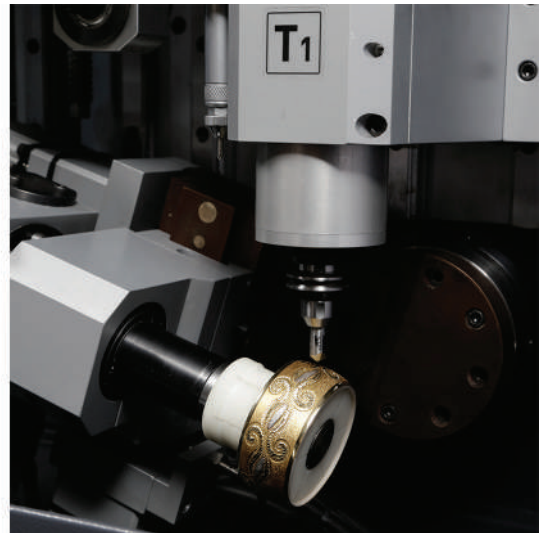
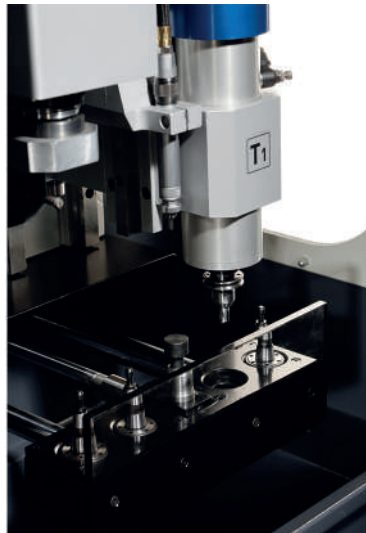
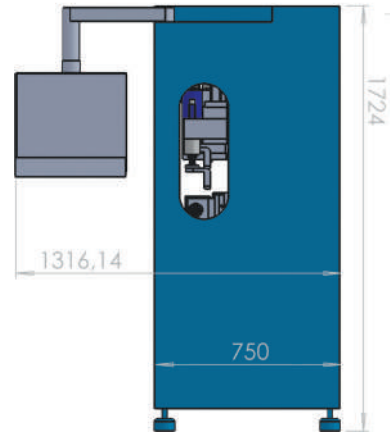
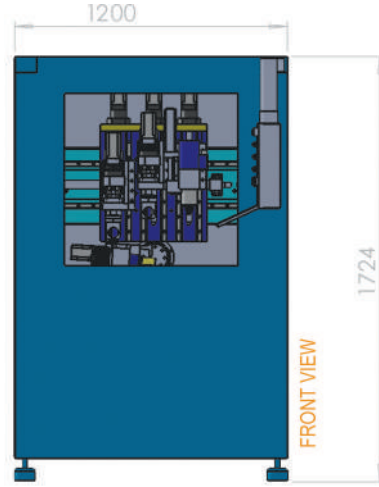

passion for  *precision*

bulunmaz.com

[f](#) / [@](#) / [v](#) / [bulunmaztools](#)



Bulunmaz Head Office Gedik Pasa Camii Sk. 51A
Cemberlitas, Istanbul-Turkey | +90 212 513 47 32 | info@bulunmaz.com